

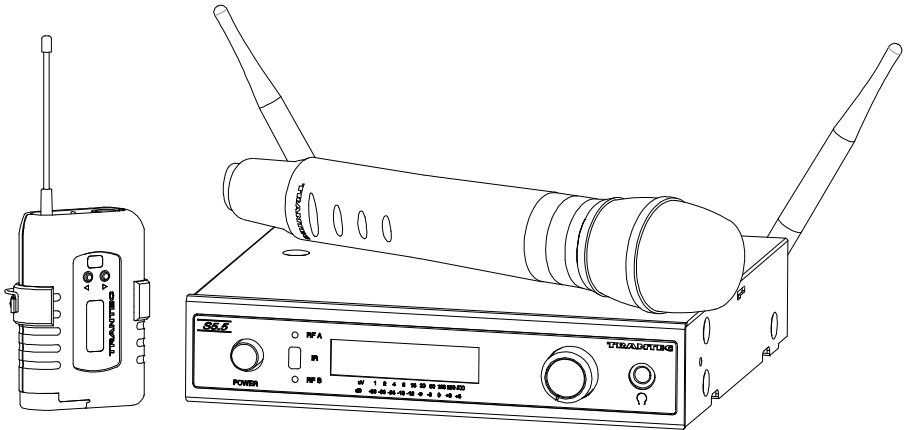

OPERATING INSTRUCTIONS

WIRELESS MICROPHONES SYSTEM S5.5 series



CONTENTS

- | | |
|---------------------------------------|---------------------------------|
| 1. SAFETY PRECAUTIONS | 8. HANDHELD MICROPHONE SET-UP |
| 2. GENERAL DESCRIPTION | 9. BELTPACK TRANSMITTER SET-UP |
| 3. FEATURES | 10. BATTERY INDICATOR |
| 4. HANDLING PRECAUTIONS | 11. S5 Series Rack Mount Kit |
| 5. NOMENCLATURE AND FUNCTIONS | 12. Mini-XLR Wiring Connections |
| 6. RECEIVER FREQUENCY SELECTION | 13. OPERATIONAL HINTS |
| 7. MISCELLANEOUS SETTINGS ON RECEIVER | 14. TROUBLESHOOTING |
| | 15. CERTIFICATIONS |
| | 16. SPECIFICATIONS |

Thank you for purchasing TOA's TRANTEC S5 series Wireless Microphone system.
Please carefully follow the instructions in this manual to ensure long, trouble-free use of your equipment.

1. SAFETY PRECAUTIONS

- Be sure to read the instructions in this section carefully before use.
- Make sure to observe the instructions in this manual as the conventions of safety symbols and messages regarded as very important precautions are included.
- We also recommend you keep this instruction manual handy for future reference.

Safety Symbol and Message Conventions

Safety symbols and messages described below are used in this manual to prevent bodily injury and property damage which could result from mishandling. Before operating your product, read this manual first and understand the safety symbols and messages so you are thoroughly aware of the potential safety hazards.



WARNING

Indicates a potentially hazardous situation which, if mishandled, could result in death or serious personal injury.

When Installing the Receiver

- Do not expose the unit to rain or an environment where it may be splashed by water or other liquids, as doing so may result in fire or electric shock.
- Use the unit only with the voltage specified on the unit. Using a voltage higher than that which is specified may result in fire or electric shock.
- Do not cut, kink, otherwise damage nor modify the power supply cord. In addition, avoid using the power cord in close proximity to heaters, and never place heavy objects -- including the unit itself -- on the power cord, as doing so may result in fire or electric shock.
- Avoid installing or mounting the unit in unstable locations, such as on a rickety table or a slanted surface. Doing so may result in the unit falling down and causing personal injury and/or property damage.
- To prevent lightning strikes, install the unit at least five meters away from a lightning rod, and yet within the protective range (angle of 45°) of the lightning conductor. Lightning strikes may cause a fire, electric shock or personal injury.
- Since the unit is designed for in-door use, do not install it outdoors. If installed outdoors, the aging of parts causes the unit to fall off, resulting in personal injury. Also, when it gets wet with rain, there is a danger of electric shock.

When the Receiver is in Use

- Should the following irregularity be found during use, immediately switch off the power, disconnect the power supply plug from the AC outlet and contact your nearest TOA dealer. Make no further attempt to operate the unit in this condition as this may cause fire or electric shock.
 - If you detect smoke or a strange smell coming from the unit.
 - If water or any metallic object gets into the unit
 - If the unit falls, or the unit case breaks
 - If the power supply cord is damaged (exposure of the core, disconnection, etc.)
 - If it is malfunctioning (no tone sounds.)
- Do not place cups, bowls, or other containers of liquid or metallic objects on top of the unit. If they accidentally spill into the unit, this may cause a fire or electric shock.
- Do not touch the unit's antennas during thunder and lightning, as this may result in electric shock.

When the Microphone or the Transmitter is in Use

- To prevent the electromagnetic wave from badly influencing medical equipment, make sure to switch off the unit's power when placing it in close proximity to the medical equipment.



CAUTION

Indicates a potentially hazardous situation which, if mishandled, could result in moderate or minor personal injury, and/or property damage.

When Installing the Receiver

- Never plug in nor remove the power supply plug with wet hands, as doing so may cause electric shock.
- When unplugging the power supply cord, be sure to grasp the power supply plug; never pull on the cord itself. Operating the unit with a damaged power supply cord may cause a fire or electric shock.

- When moving the unit, be sure to remove its power supply cord from the wall outlet. Moving the unit with the power cord connected to the outlet may cause damage to the power cord, resulting in fire or electric shock. When removing the power cord, be sure to hold its plug to pull.
- The socket outlet shall be installed near the equipment and shall be easily accessible.
- Avoid installing the unit in humid or dusty locations, in locations exposed to the direct sunlight, near the heaters, or in locations generating sooty smoke or steam as doing otherwise may result in fire or electric shock.

When the Receiver is in Use

- Do not place heavy objects on the unit as this may cause it to fall or break which may result in personal injury and/or property damage. In addition, the object itself may fall off and cause injury and/or damage.
- Make sure that the volume control is set to minimum position before power is switched on. Loud noise produced at high volume when power is switched on can impair hearing.
- Never open the unit case as there are high temperature parts inside the unit, which may cause a burn if touched. Refer all servicing to your nearest TOA dealer.
- Use the dedicated AC adapter for the unit. Note that the use of other adapter may cause a fire.
- If dust accumulates on the power supply plug or in the wall AC outlet, a fire may result. Clean it periodically. In addition, insert the plug in the wall outlet securely.
- Switch off the power, and unplug the power supply plug from the AC outlet for safety purposes when cleaning or leaving the unit unused for 10 days or more. A fire or electric shock may result.
- Any modifications made to this device that are not approved by TOA Corporation may void the authority granted to the user to operate this equipment.
- Operation of this device is subject to the following two conditions: (1) this device may not cause interference, and (2) this device must accept any interference, including interference that may cause undesired operation of the device.

When the Microphone or the Transmitter is in Use

- When the unit is not in use for 10 days or more, be sure to take the battery out of the unit because battery leakage may cause personal injury or contamination of environment.
- Make sure to observe the following handling precautions so that a fire or personal injury does not result from leakage or explosion of the battery.
 - Do not short, disassemble heat nor put the battery into a fire.
 - Do not solder a battery directly.
 - Be sure to use the specified type of battery
 - Note correct polarity (positive and negative orientation) when inserting a battery in the unit.
 - Avoid locations exposed to the direct sunlight, high temperature and high humidity when storing batteries.
- When the battery becomes inflated or leaks, discontinue use and replace with new one immediately

CAUTION TO USER: Changes or modifications not expressly approved by the party responsible for compliance could void the user's authority to operate the equipment.

IMPORTANT NOTE: To comply with the FCC RF exposure compliance requirements, no change to the antenna or the device is permitted. Any change to the antenna or the device could result in the device exceeding the RF exposure requirements and void user's authority to operate the device.

IMPORTANT NOTE:

This device complies with Industry Canada's licence-exempt RSSs. Operation is subject to the following two conditions:

(1) This device may not cause interference; and (2) this device must accept any interference, including interference that may cause undesired operation of the device.

Le présent appareil est conforme aux CNR d'Industrie Canada applicables aux appareils radio exempts de licence. L'exploitation est autorisée aux deux conditions suivantes : (1) l'appareil ne doit pas produire de brouillage, et (2) l'utilisateur de l'appareil doit accepter tout brouillage radioélectrique subi, même si le brouillage est susceptible d'en compromettre le fonctionnement.

2. GENERAL DESCRIPTION

The TOA's TRANTEC S5 series Wireless Microphone system is designed for use on the UHF frequency band, and suitable for vocal or speech reinforcement applications. It features a compander circuit which minimizes the influence of ambient noise.

24 User selectable channels that can be operated simultaneously. (depending on region)

10 preset banks including 1 custom user.

S5 series HDX Wireless handheld Microphone employs a fine, powerful dynamic microphone unit.

S5 series HCX Wireless handheld Microphone employs a fine condenser microphone unit.

S5 series BTX Wireless belt-pack transmitter can use TRANTEC series lavalier microphones and headset microphones .

S5 series RX Wireless receiver is a true diversity receiver to minimize drop-outs.

3. FEATURES

- An optimized PLL-synthesizer minimizes the oscillation frequency drift resulting from the ambient temperature or voltage fluctuation.
- Intuitive LCD and operating system on both receiver and transmitter.
- Infra-red programming for fast system set-up.
- Software transmitter function locks.
- Headphone monitoring as standard.
- Up to 10 hours of continuous use with single AA alkaline battery.
- S5 series handheld microphone employs a built-in antenna.
- The state of battery consumption can be displayed on S5 series RX receiver's indicator.
- Quick channel scanning.
- AF processing menu.
- Fully integrated PC software monitoring facility via USB port.
- All metal construction of receiver and transmitters.
- Rack kit and front mounting antenna adaptors included.
- Compact size and high reliability

4. HANDLING PRECAUTIONS

- Do not expose the unit to rain or an environment where it may be splashed by water or other liquids, as doing so may result in unit failure.
- Never open nor remove the unit case to modify the unit. Refer all servicing to your nearest TOA dealer.
- Take care not to drop the unit onto the floor nor bump it against a hard object as the unit could fail.
- Do not place the unit in locations of high temperature (ex. in an ill-ventilated car in summer) or high humidity as the unit could fail.
- Do not use the unit in locations where it is exposed to seawater.
- Avoid using a mobile telephone near the wireless microphone in use. Noise could be picked up.
- When installing, keep the unit as far away as possible from fluorescent lamps, digital equipment, personal computers, and other equipment that generate high frequency noise.
- To clean, use a dry cloth. When the unit gets very dirty, wipe lightly with a cloth damped in a dilute neutral cleanser, then wipe with a dry cloth. Never use benzene, thinner, or chemically-treated cleaning towel.
- When using two or more wireless microphones, keep them at least 50 cm away from each other to avoid malfunctions or noise.
- Keep the wireless microphone at least 3 m away from the receiving antenna. Using the microphone in close proximity to the antenna could result in malfunctions or noise.
- Never position the transmitter antenna directly against the body or hand. This will have the effect of reducing the operating range considerably.
- Keep the microphone/instrument lead away from the antenna on the beltpack.

5. NOMENCLATURE AND FUNCTIONS

Receiver : S5.5-RXA [Front]

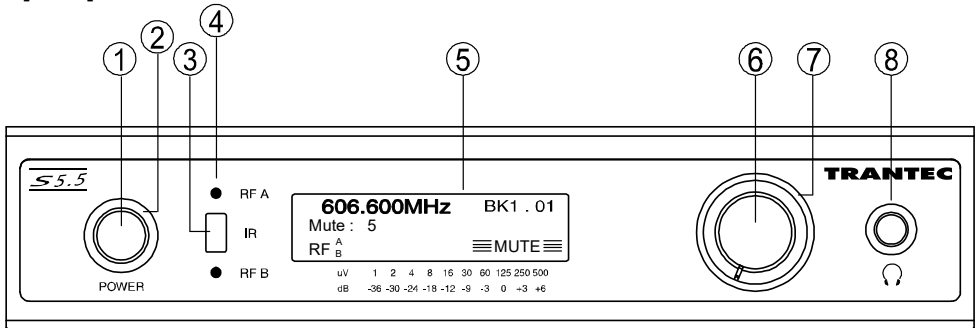

1. Power switch

Press this switch to turn the power on, and press it again to turn off the power.

2. Power indicator

Depending on the state of the power switch, the indicator lit or unlit state will be determined as follows.

The supplied AC adapter is connected to the receiver, but the power switch is turned off.	Lit (red)
The power switch is turned on with connecting the supplied AC adapter to the receiver.	Lit (blue)

3. Infrared (IR) port

Transmit the infrared signal for the setting of the transmitter.

4. Reception lamps [RF A, RF B]

Either lamp of RF A or RFB lights red when the receiver matches a radio signal from the transmitter.

5. LCD screen

Displays the receiving status when the unit is in normal operating state.

In setting mode, the screen displays the setting items and their contents.

6. Jog wheel

Rotate and press this knob to change the setting parameters or select the setting contents on the setting screen.

7. Mute indicator

Depending on the state of reception, the indicator lit or unlit state will be determined as follows.

When being received normally ^{*1}	Lit (green)
Muting condition ^{*2}	Lit (red)

^{*1} While receiving radio waves and when audio output is in a ready state.

^{*2} While receiving radio waves, in the state when audio output does not occur. Or when reception does not occur.

8. Headphone output

1/4" jack socket

[Rear]

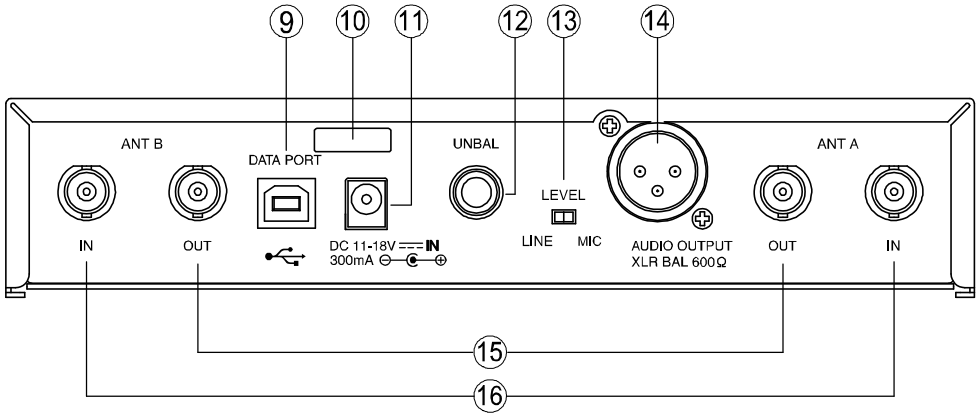

9. USB port

Used to connect the unit to a PC with the installed software.

10. Cable hanger

Hook the power cable onto this part.

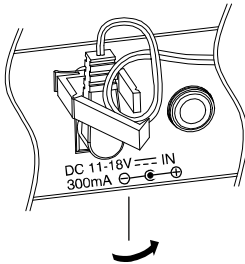

11. DC input jack

Connect the power cable of the supplied AC adapter to this jack.

12. AF output

Unbalanced 1/4" jack socket, male type
+9 dBm (maximum)

13. AF output level selector

Sets the output level from the AF outputs by selecting either MIC or LINE

14. AF output

MIC / LINE selectable, balanced, XLR connector, male type

LINE level : +15dBm (maximum)

MIC level : -25dBm (maximum).

15. Antenna distribution outputs A, B

50 ohm, BNC

Output the same signals as those which are input to Antenna inputs A, B. Used for an RF cascade connection.

16. Antenna inputs A, B

50 ohm, BNC

Phantom powering for the external antenna (optional)

For the wireless system covering a relatively narrow area, use the supplied two rod antennas, which should be set up at 45° outwards from a vertical line.

Handheld microphone : S5.5-HDX2 & S5.5-HC2

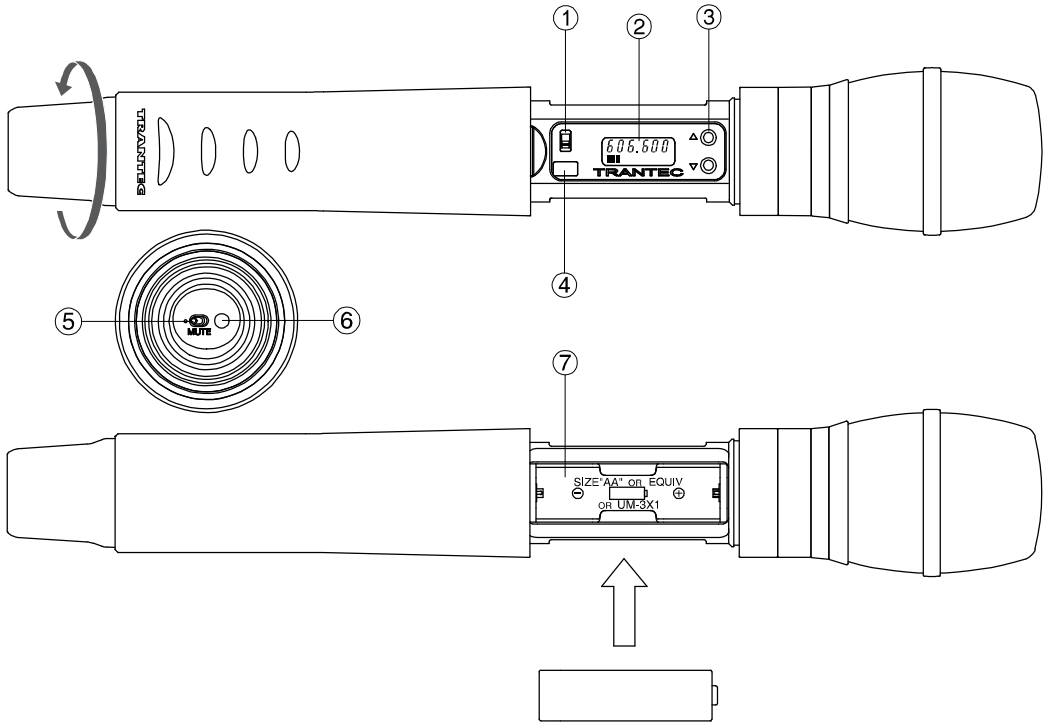

1. Power switch

Slide this switch towards "ON" position to turn the power on, and slide it again towards "OFF" position to turn off the power.

2. LCD screen

Displays the state of the unit.

3. Up down key [▲ ▼]

Used to select the channel (frequency) and AF gain. (The frequency must be identical to that of the receiver.)

4. Infrared (IR) port

Receive the infrared signal from the receiver to set-up the transmitter.

5. Muting switch

Flick this switch towards the power lamp to mute the audio.

6. Power lamp

A blue LED lights with turning on the power switch.

7. Battery compartment

Insert an AA battery according to (+) and (-) indications on the battery compartment.

Note Turn off the power switch.

Belt-pack transmitter : S5.5-BTX2

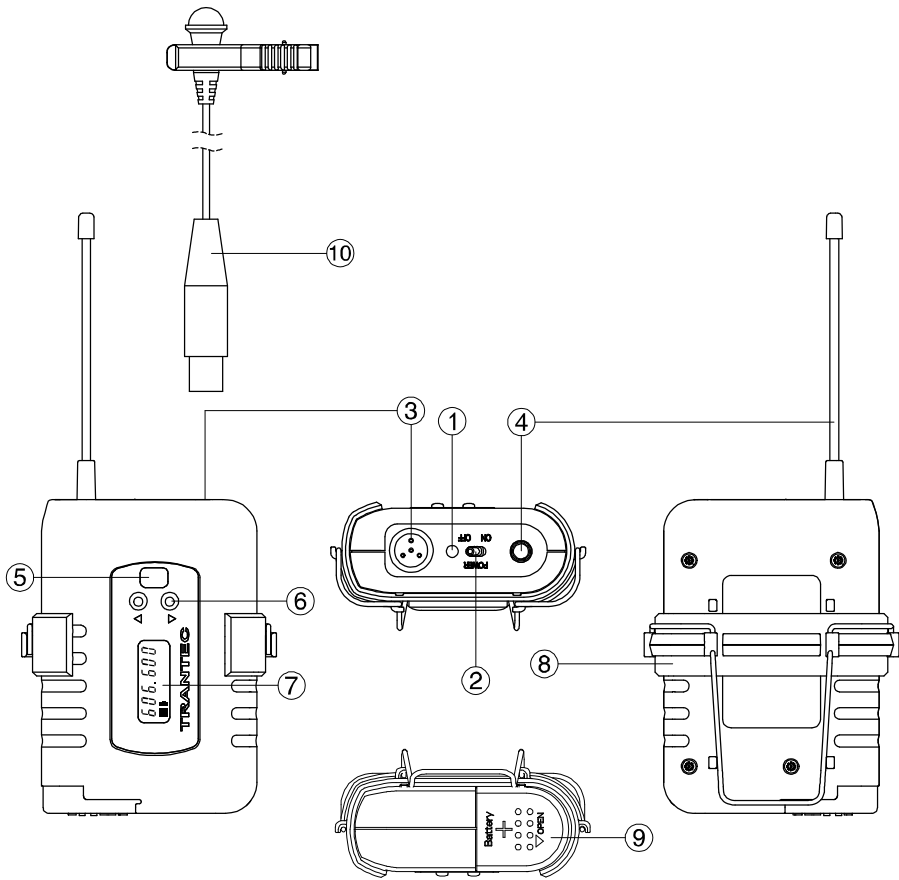

1. Power lamp

A blue LED lights with turning on the power switch.

2. Power switch

Slide this switch towards "ON" to turn the power on, and slide it again towards "OFF" to turn off the power.

3. Input connector

Mini-XLR socket, Connect the microphone or the instrument cable.

4. Antenna

Note Never position the transmitter antenna directly against the body or hand. This will have the effect of reducing the operating range considerably. Used to select the channel (frequency). (The frequency must be identical to that of the receiver.)

5. Infrared (IR) port

Receive the infrared signal from the receiver.

6. Up down key [▲▼]

Used to select the channel (frequency) and AF gain. (The frequency must be identical to that of the receiver.)

7. LCD screen

Displays the state of the unit.

8. Clip

Clip the transmitter to a belt through the transmitter clip. It is better the belt should be pressed against the base of the transmitter clip.

9. Battery compartment

Insert an AA battery according to (+) indications on the battery door.

Note: Turn off the power switch.

10. Microphone

Note: Route the microphone cable so as to avoid undue strain of friction. Try and keep the microphone cable away from the antenna.

6. RECEIVER FREQUENCY SELECTION

6-1. To change the selected channel in BANK

- Step 1.** Press and hold the “Jog-wheel” for approximately 3 seconds if the receiver is not in mute to enter the **MAIN MENU**. You will enter the **MAIN MENU** immediately if the receiver is in mute.
- Step 2.** With **FREQ SEL** (Frequency selection) underlined press the “Jog Wheel”. This will give you the next menu.
- Step 3.** Rotate the “Jog Wheel” until **BANK** is underlined and press to give you the Bank selection screen below right.
- Step 4.** Rotate the “Jog Wheel” to underline the number of a new bank, then press to select.
- Step 5.** Rotate the “Jog-wheel” to change the channel within this bank, and press to select the frequency shown.
- Step 6.** Rotate and press again with **ACCEPT** underlined to accept the new bank and frequency, and return to the normal display state.

Note Make sure that the transmitter is identical to the receiver in the channel number. Should the microphone’s setting differ from that of the receiver, the receiver does not receive the radio signal from the transmitter.

```

MAIN MENU
FREQ SEL RX SET
EXIT TX SET
    
```

```

FREQUENCY SELECT
SINGLE USER BANK
EXIT SCAN
    
```

```

1 2 3 4 5 6 7 8 9
Rotate— Change Bank
Press— Select Bank
    
```

```

1 2 3 4 5 6 7 8 9
Rotate— Change Bank
Press— Select Bank
    
```

```

606.600MHz BK2 .01
Rotate— Change
Press— Select
    
```

```

606.600MHz BK2 .01
EDIT CANCEL
ACCEPT
    
```

6-2. To change the selected channel to a Custom single frequency

- Step 1.** This option allows the customer to select 1 of over 1400 available channels. Press and hold the “Jog-wheel” for approximately 3 seconds if the receiver is not in mute to enter the **MAIN MENU**. You will enter the **MAIN MENU** immediately if the receiver is in mute.
- Step 2.** With **FREQ SEL** (Frequency selection) underlined press the “Jog Wheel”. With **SINGLE** underlined press the “Jog-wheel”.
- Step 3.** With **EDIT** underlined press the “Jog- wheel”. The first part of the frequency will be flashing. Rotate the “Jog-Wheel” to select this section of a new frequency and press to accept. The second part of the frequency will now start flashing. Change the second part of the new frequency as above.
- Step 4.** You can then change each letter of the user name in the same way. All ASCII characters are available for the user name.
- If you wish to exit this menu at any time, press and hold the “Jog-Wheel”.
- Step 5.** Press the “Jog-Wheel” for 1 second to exit then rotate till **ACCEPT** is underlined and press to select the new custom frequency and user name.

Note In the case of the S5.5 it will be added to the Custom **USER** bank. You can download **USER** banks via the TRANTEC software. Please refer to the software manual on this CD for more information.

```

FREQUENCY SELECT
SINGLE USER BANK
EXIT SCAN
    
```

```

606.750MHz Perf 1
EDIT CANCEL
ACCEPT
    
```

```

606.600MHz Steve 1
EDIT CANCEL
ACCEPT
    
```

6-3. To Program a transmitter with Bank information via receiver Infrared port

Step 1. Press and hold the "Jog-wheel" for approximately 3 seconds if the receiver is not in mute to enter the MAIN MENU. You will enter the MAIN MENU immediately if the receiver is in mute.



Step 2. Rotate the "Jog Wheel" till **TX SET** is underlined and press to enter **TX SETTINGS**. With **FREQUENCY** underlined, press the "Jog Wheel".

Step 3. Align the transmitter and receiver infra-red windows with the transmitter no more than 15 cm from the receiver. With **SEND** underlined, press the "Jog Wheel" and wait a few seconds. All frequencies in the bank selected will be transferred to the transmitter and its current frequency will be set to match the receiver's current frequency. The receiver will return to its main display.



Note If the receiver is currently in a **SINGLE** or **USER** frequency, it will transfer the **USER** bank.

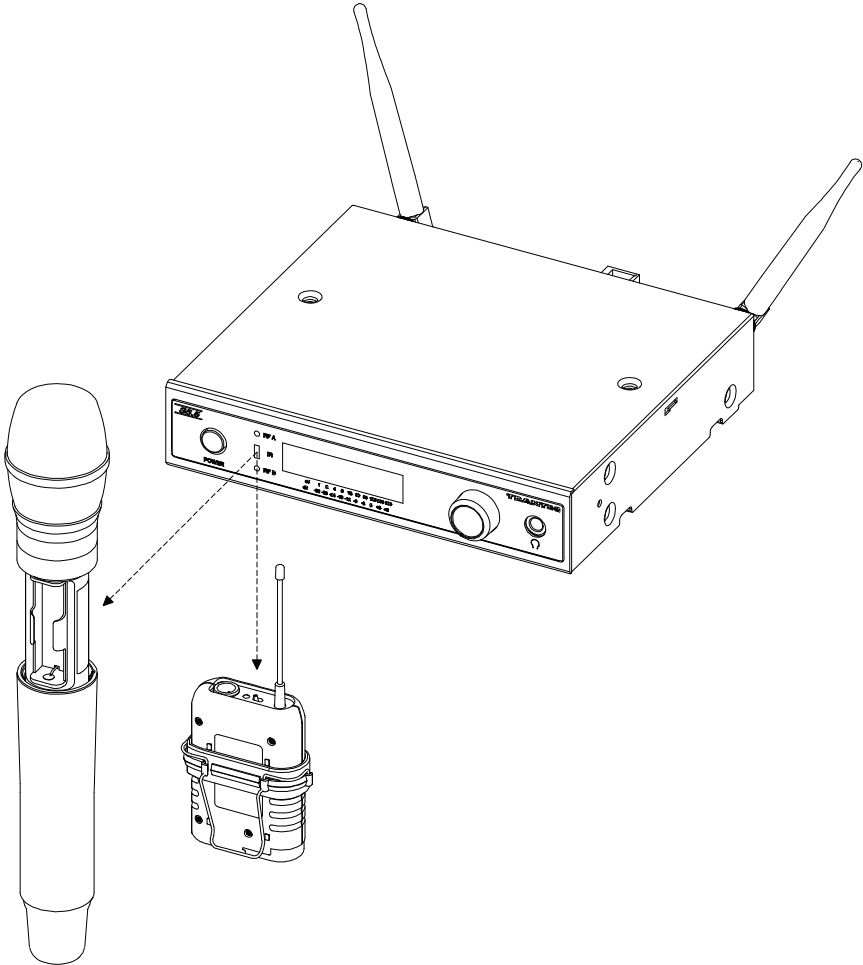

7. MISCELLANEOUS SETTINGS ON RECEIVER

7-1. Mute/Squelch Settings

The S5 series uses sophisticated internal mute functions including Pilot Tone, Noise and RSSI to prevent noise break through from external sources when the transmitter is in the "OFF" position. The RSSI (Received signal strength) portion is user adjustable via the **RX SETTINGS** menu.

Step 1. To Access **RX SETTINGS** press the "Jog-Wheel" for 1 second and enter the **MAIN MENU**, or for 3 seconds if not in mute.



Step 2. Rotate till **RX SET** is underlined and press. With **MUTE** underlined, press the "Jog-Wheel".

Step 3. Now rotate the "Jog- Wheel" to adjust the mute setting between 1 and 10, then press. A marker shows the current mute setting in relation to the RF A and B scales.



Note High mute settings will decrease range and low mute settings increase the interference potential. We recommend a setting of 4 to 6. The mute level changes in real time as the setting is varied.



Ensure the correct setting of the Mute for effective control of interference whilst the transmitter is turned off. The default is normally 5 but may need to be increased with multi-channel set-ups.

7-2. Audio Processing

Step 1. Press the "Jog-Wheel" to enter the **MAIN MENU**. Rotate till **RX SET** is underlined then press. On the **RX SETTINGS** menu, rotate till **AUDIO** is underlined and press.

Options available in **AUDIO** menu are **PHASE REV**, **LoCUT**, and **HiBOOST**. The default factory setting for all these options is OFF.

PHASE REV – reverses the audio output phase.

LoCUT – reduces the low frequency response.

HiBOOST – increases the high frequency response.

Step 2. Navigate to each option by rotating the "Jog-Wheel" and press to check the box for each option when it is underlined. All three of the above functions change in real time as the option is selected.



Step 3. Rotate the "Jog-Wheel" to underline **EXIT** after making your selections, and press to return to the main screen.



7-3. Headphone Volume

Step 1. Rotate the "Jog-Wheel" while the main screen is showing to go to the headphone volume adjustment.

Step 2. A bar graph of the volume is shown and can be altered by again turning the "Jog-Wheel".

Step 3. Push to exit and return to the main screen. The unit will return to the main screen automatically if there is no user intervention for approximately 2 seconds. Any change you have made will be saved.



7-4. Channel Scan

The scanning feature can determine which frequencies are currently being used in the vicinity of your receiver.

Step 1. From the main screen press the “Jog- Wheel” to go to **MAIN MENU**, rotate till **FREQ SEL**, is underlined and push.



Step 2. Then rotate till **SCAN** is underlined and push. The scanning process takes about 10 seconds and you will then be shown the Bank selection screen. If interference is found on a frequency during the scan, the bank containing that frequency is made unavailable on the receiver. You can then select any bank from those available, and any frequencies from within those banks.



Note Multiple System Setup

- The proper operation of your wireless system may be interfered with by other system operating on the same frequency. In such cases, change the operating frequency of your system.
- Do not mix separate Banks in multi-channel set-ups.
- Use the SCAN function to check for external interference.
- Set up each system one at a time, confirm each system is assigned a different channel, and leave the transmitter powered on. Otherwise, the channel scan from the other receiver will not detect as the occupied channel.

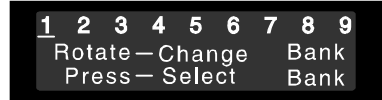

7-5. Pilot Tone

The S5 series has the ability to disable the pilot tone as a means of either identifying outside interference or allowing compatibility with non-pilot tone devices. The default factory setting is ON.

Step 1. To disable Pilot Tone press the “Jog- Wheel” to go to **MAIN MENU**. Rotate till **RX SET** is underlined and push to go to the **RX SETTINGS** menu.



Step 2. Rotate the “Jog-Wheel” to underline **PILOT** and press to uncheck the box.



Step 3. Rotate the “Jog-Wheel” to underline **EXIT**, and press to return to the main screen.



7-6. Phantom Power

DC added to the antenna inputs for powering head amplifiers. The default factory setting is OFF.

Step 1. Push the “Jog- Wheel” to show the **MAIN MENU**. Rotate the “Jog-Wheel” to underline **RX SET**, and push to show the next **RX SETTINGS** menu.



Step 2. Rotate to underline **PHANTOM**, and push. Press to check the **PHANTOM PWR** box.



Step 3. Rotate and then press to choose **EXIT** and return to the main screen.



7-7. LCD Contrast

- Step 1.** Push the "Jog-Wheel" to bring up the **MAIN MENU**. Rotate the "Jog-Wheel" to underline **RX SET** and push.
- Step 2.** Rotate to underline **LCD** and push, then rotate the "Jog-Wheel" to alter the **LCD CONTRAST**.
- Step 3.** Push to exit and return to the main screen. The unit will return to the main screen automatically if there is no user intervention for approximately 2 seconds. Any change you have made will be saved.



7-8. Lock TX switch

To prevent unauthorised or accidental changes of frequency or gain on a transmitter, or accidentally turning a transmitter off during a performance you can lock these features from the receiver.

- Step 1.** Press the "Jog-Wheel" to show the **MAIN MENU**. Rotate the "Jog-Wheel" to underline **TX SET** and push to select this option.
- Step 2.** Rotate the "Jog-Wheel" till **LOCK** is underlined and push to select this. Push the "Jog-Wheel" to check the box for **POWER** if required, or rotate to go to **FREQ/GAIN** and push to check this box if required.
- Step 3.** Rotate till **EXIT** is underlined and push. You will then have the option to **SEND** the TX Locks you have selected, to a transmitter or **CANCEL**. If you are sending Locks to a transmitter you should hold it within 15cm of the receiver and with the infra-red windows of each aligned.



8. HANDHELD MICROPHONE SET-UP

Step 1. Opening the microphone

Undo the handheld sleeve by unscrewing the end cap at the base anti-clockwise and then gently sliding the sleeve down to expose the LCD and Battery compartment.

Step 2. Battery fitting

Place an Alkaline "AA" cell into the battery compartment noting the correct polarity as shown on the label in the compartment.

Step 3. Switch on

Slide the On/Off switch to the "On" position and observe the display is on and the Power On LED located in the end cap is illuminated.

Step 4. Check for received signal

Check that the display indicates the same channel as the receiver. The receiver should now show a received signal on its RF bar graphs and after 20 seconds the transmitter battery status.

Step 5. Frequency adjustment

Turn on the transmitter and adjust the frequency whilst the "decimal point" is flashing (approx. 6 secs) via the "Up" or "Down" buttons. When the correct frequency is selected, turn the transmitter off then on again to activate the newly selected channel.

Step 6. Gain adjustment

Turn on the transmitter and wait for the flashing "decimal point" on the LCD to stop flashing. Press the "Up" or "Down" buttons to increase or decrease the head sensitivity. The display will show 0-5, with "0" gain being for max SPL.

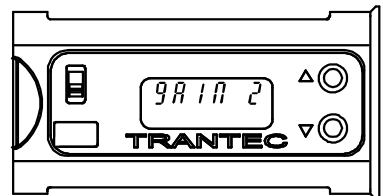

Step 7. Mute switch

Incorporated in the handheld end cap is a Power On LED and Audio Mute switch. To mute the audio, flick the switch towards the LED. Turn on Audio Mute switch, Power On LED blinks. Turn on Power Switch with audio muting, after Power On LED lights for 30 sec, starts blinking.

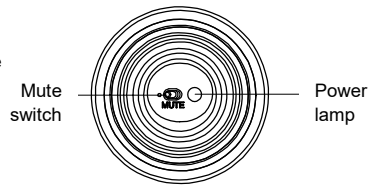

9. BELTPACK TRANSMITTER SET-UP

Step 1. Battery fitting

Open the battery compartment by sliding the door forward and up. Insert a battery observing the correct polarity as shown. The door is marked with a "Battery +".

Step 2. Antenna fitting

Screw the antenna into the antenna bush.

Step 3. Microphone

Plug a mic into the Mini-XLR socket.

Step 4. Switch on

Flick the On/Off switch to the "On" position and observe the display is on and the battery LED illuminated. Check the display indicates the same channel as the receiver.

Step 5. Check for received signal

Check that the display indicates the same channel as the receiver. The receiver should now show a received signal on its RF bar graphs and after 20 seconds the transmitter battery status.

Step 6. Frequency adjustment

Turn on the transmitter and adjust the frequency whilst the "decimal point" is flashing (approx. 6 secs) via the "Up" or "Down" buttons. When the correct frequency is selected, turn the transmitter off then on again to activate the newly selected channel.

Step 7. Gain adjustment

Turn on the transmitter and wait for the flashing "decimal point" on the LCD to stop flashing. Press the "Up" or "Down" buttons to increase or decrease the AF gain. The display will show 0-9, with "0" gain being for minimum.

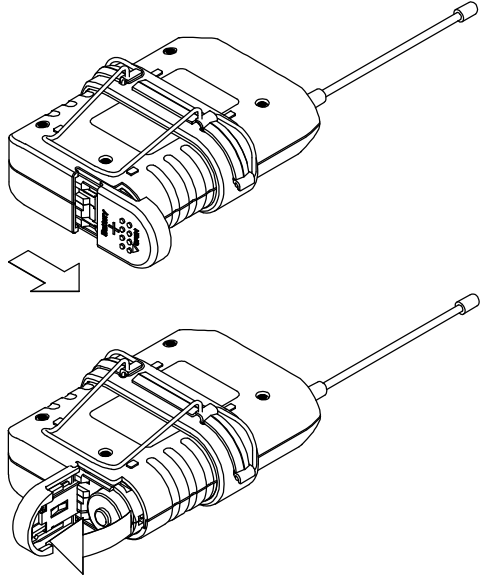

10. BATTERY INDICATOR

When the battery capacity in the corresponding transmitter becomes low, the display of the LCD on the receiver and the transmitter indicate the transmitter's remaining battery capacity. Replace the transmitter battery.

<p>Transmitter Receiver</p>	<p>Transmitter Receiver</p>	<p>Transmitter Receiver</p>
<p>Battery capacity is full.</p>	<p>Battery capacity depletion has started.</p>	<p>Battery capacity is almost depleted, and battery replacement is required.</p>

11. S5 Series Rack Mount Kit

11-1. 19" Rack Mounting for 2 x S5 Series Receivers

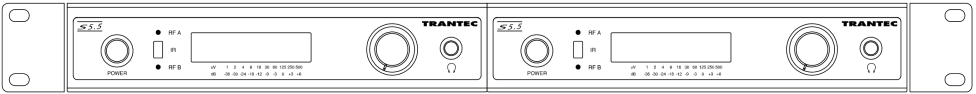

The rack mounting kit is supplied as standard with S5.5 systems.

Step 1.

Unscrew the front 3 lid retaining screws from opposite sides of each receiver case and fit the angled rack brackets, using the supplied screws. There are 3 of these supplied with each receiver.

Step 2.

Remove the 2 plastic plugs from the top of the receiver lid and fit a metal joining strip (2 supplied per receiver) in the slots at the side of each lid of the 2 receivers. Carefully fit the M3x6 screws (1 supplied with each receiver, colored black).

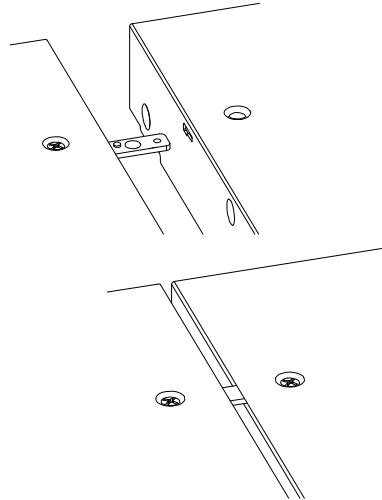
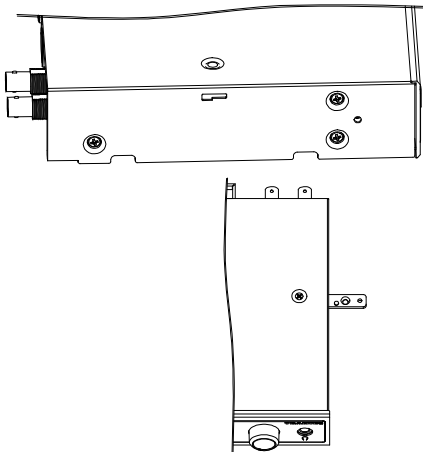
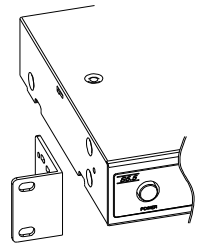

Step 3.

Fit 2 joining strips across the bottom of the receiver chassis using 4 M3x6 CSK screws (2 supplied per receiver).

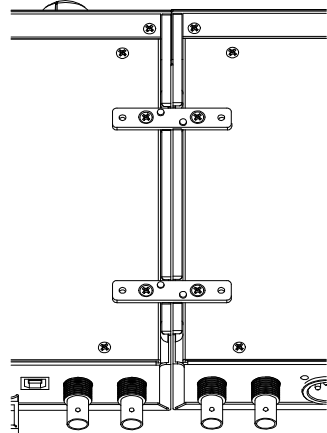

11-2. 19" Rack 1 x S5 Series Receiver with Front Mount Antenna

The rack mounting kit is supplied as standard with S5.5 systems.

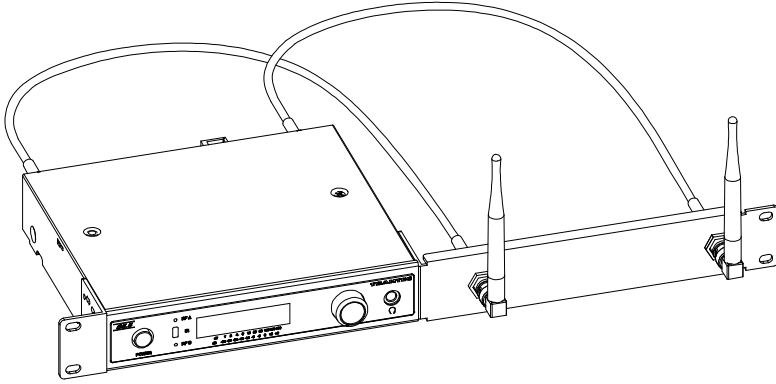

Step 1.

Unscrew 3 x lid retaining screws (M3x6) from the front left side of the chassis (viewed from the front) and fit the small angled rack bracket, using the supplied screws. There are 3 of these supplied with each receiver.

Step 2.

Unscrew 3 x lid retaining screws (M3x6) from the front right side of the chassis and fit the supplied long angled bracket using the screws supplied.

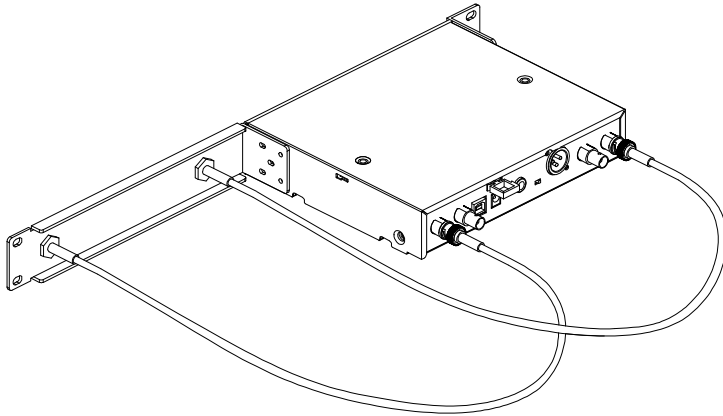

Step 3.

Fit the 2 supplied antenna extension cables into the front panel long bracket and tighten their BNC nuts. Screw the BNC plugs of each into the antenna sockets on the rear of the receiver. Should front mount antennae not be required, fit the 2 plastic blanking plugs supplied into the spare holes.

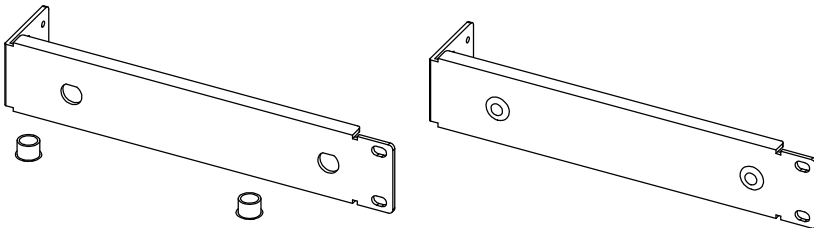

12. Mini-XLR Wiring Connections

Beltpack Audio Mini-XLR Connections

1. Ground
2. Bias 5 V
3. AF Hi-Z
4. AF Load Resistor

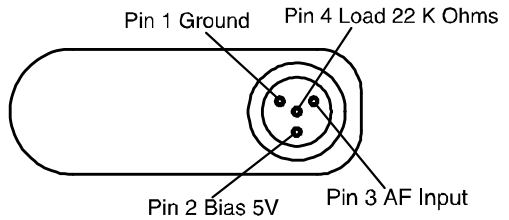

Solder connections for Mini-XLR flying socket

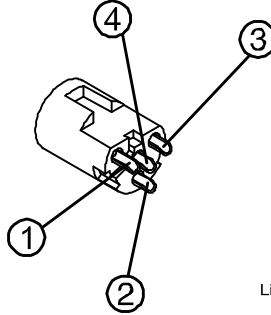

12-1. Wiring for Mini-XLR Flying Socket

2 Wire Mic

Pin 1: Ground Pin 2: 5 V

Pin 3: AF

Pin 4: Internal AF load resistor

Link pins 3 and 4 and add a 10 KΩ bias resistor as illustrated

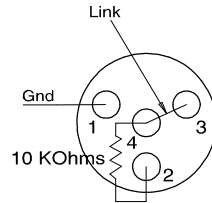

3 Wire Mic

Pin 1: Ground Pin 2: 5 V

Pin 3: AF

Pin 4: Internal AF load resistor

Link pins 3 and 4 as illustrated

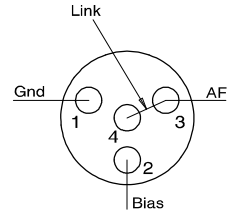

Hi Impedance Guitar/Instrument

Pin 1: Ground

Pin 2: 5 V - Not connected

Pin 3: AF Hi Z

Pin 4: Not connected

Connect screened cable to pin 1 ground and pin 3 AF Hi-Z

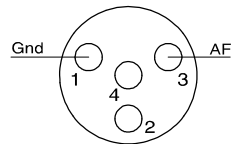

Lo Impedance Microphone (No Phantom)

Pin 1: Ground

Pin 2: 5 V - Not connected

Pin 3: AF Hi-Z

Pin 4: Internal AF load resistor

Link pins 3 and 4 and connect screened cable to pin 1 ground and pins 3 and 4 as illustrated

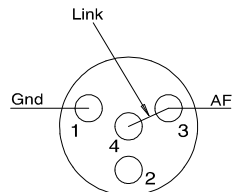

13. OPERATIONAL HINTS

- When the transmitter user moves in a facility, signal dropouts (momentary losses of signal reception) may be encountered. These dropouts are caused by the building's architectural designs or materials which block the travel of or reflect the radio signal. If this occurs, the user needs to change locations for better signal reception.
- Confirm the good line of sight between the transmitter and the receiver. Do not place the large obstructions (ex. Concrete walls or large metal obstructions) between the transmitter and the receiver. In addition keep the receiver away from the metallic beams and obstructions as these can adversely affect the antenna pick-up pattern and induce the interference.
- Set the transmitter AF gain so the receiver VU indicates 0 db with occasional peaks to +6 dB.
- Hold the microphone within 20cm from the sound source. Move the microphone closer for a warmer sound increased. And do not cover the grille with hand.
- Keep your mouth 15 – 20 cm away from the lavalier microphone for the best possible sound reproduction. In case of the Omni-directional response, it will pick up sounds from all directions. It is better that the microphone is placed closer to the sound source. Take care not to bring your mouth too close to the microphone (within 5 cm) as this impairs speech clarity if you speak loudly.
- In case of the headset microphone, by adjusting the gooseneck, locate the microphone with the supplied windscreen in front of your mouth, and position it 3 – 5 cm away from your mouth for the best sound reproduction. When the microphone is too close to your mouth or you speak too loud, speech clarity will be impaired, making it hard for the audience to hear announcements.

14. TROUBLESHOOTING

Issue	Condition	Solution
No operation of Transmitter	Check the capacity of the battery	Replace the current battery with a fresh one of the correct Alkaline "AA" type.
No RF signal on receiver	Receiver Reception lamps [either A or B] , mute indicator , and RF signal level meter do not light.	Check the transmitter and receiver are "Tuned" to the same channel.
No sound	Receiver Reception lamps [either A or B] or RF signal level meter lights.	Confirm the connections of all sound system or gain.
Sound distorted	VU bar graph on the receiver shows too high.	Confirm the transmitter gain. Reduce the gain of the transmitter if the VU meter shows over 6dB. Confirm the receiver XLR mic-line switch for a correct match to your Mixer/Amplifier.
AF Signal low level with high background noise	VU bar graph on the receiver shows low.	Adjust the transmitter gain so the VU bar graph shows 0dB with 6dB peaks.
External Head amplifiers not operating	Receiver Reception lamps [either A or B] , mute indicator , and RF signal level meter do not light.	Check for shorts in the leads and ensure the receiver PHANTOM PWR is switched on via the RX SETTINGS menu.
Receiver LCD contrast poor	Check the LCD contrast.	Enter the receiver RX SETTINGS menu, select LCD and press then rotate the "Jog-Wheel" to adjust the contrast.

<p>Poor range or sound dropouts</p>	<p>Receiver Reception lamps [A and B] are flicking or RF signal level meter turn light off..</p>	<p>The system must be set up within recommended range.</p> <p>The transmitter must be used in line of sight from the receiver.</p> <p>Check the channel scan, confirm nearby source of interference, and change the receiver and the transmitter to a different channel.</p> <p>Check the mute level setting. For normal range we recommend a mute setting of 4-6.</p> <p>Confirm the battery indication, and replace the transmitter battery.</p>
-------------------------------------	--	--

15. CERTIFICATIONS

In compliance with

RED:

EN 301 489-1 V2.2.0 (2017-03)
 EN 301 489-9 V2.1.1 (2017-03)
 EN 300 422-1 V2.1.2 (2017-01)
 EN 62368-1: 2014+A11: 2017

RoHS:

EN 50581: 2012

CE Declaration of Conformity

2014/53/EU RED
 2011/65/EU RoHS

Traceability Information for Europe

Manufacturer:

TOA Corporation
 7-2-1, Minatojima-Nakamachi, Chuo-ku, Kobe,
 Hyogo, Japan

Authorized representative:

TOA Electronics Europe GmbH
 Suederstrasse 282, 20537 Hamburg, Germany
 URL: www.toa.de

16. SPECIFICATIONS

System

Modulation	Wideband FM
Frequency Range	UHF band (606-638 MHz), 10 banks x 24 channels (max.)
RF switching band width	36 MHz typ.
Tunable Frequencies	25 kHz Steps
Pilot tone	32.768kHz
Total Harmonic Distortion	< 0.8 % @1kHz deviation 22 kHz
Function	IR sync, Channel scan, Battery life information
Dynamic Range	>110 dB(A)
Operating Temperature Range	-10°C to +50° C

TRANSMITTER

	S5.5-HDX2, S5.5-HCX2	S5.5-BTX2
Microphone unit	Dynamic with cardioid pattern (HDX) Electret condenser with cardioid pattern (HCX)	TRANTEC series lavalier and head set microphone
RF Carrier Power	10 mW	10 mW
Audio Frequency Response	100 - 12000 Hz (HDX) 200 - 16000 Hz (HCX)	50 - 18000 Hz
Audio input Level	140 dB SPL (maximum)	-6dBV (maximum), mic gain 0dB
Battery Life	approx. 8 hours	approx. 8 hours
Power Supply	1 AA size alkaline battery, 1.5 V	1 AA size alkaline battery, 1.5 V
Finish	Body : Aluminium, black, paint Microphone head : Steel, black, paint	Aluminium, black, paint
Dimensions*	φ 48 x 245 mm	55 (W) x 80 (H) x 22 (D) mm (with clip)
Weight*	(HDX) 305 g (with battery) (HCX) 275 g (with battery)	105 g (with battery)

RECEIVER

	S5.5-RXA
Diversity Reception	Dual Diversity featuring PLL Dual Double conversion receivers
Sensitivity	1μV at 12 dB SINAD
Squelch (SQ)	Tone SQ, Carrier SQ, Noise SQ
Carrier SQ range	10 steps 30 dB
Antenna Inputs	BNC 50 ohm (phantom powering for antenna) 9 V DC, 60 mA short-circuit protected on each RF port
Antenna Outputs	BNC 50 ohm (Gain 0 dB)
Audio Frequency Response	50 - 20000 Hz
Audio Output Level (Maximum)	Balanced (XLR socket) LINE level : +15 dBm MIC level : -25 dBm Un-balanced (1/4" jack socket) : 9 dBm
Power Supply	12 VDC 300 mA
Dimensions*	210 (W) x 46 (H) x 210 (D) mm (excluding antenna)
Weight*	1.3 kg

0dBu=0.775V

Note: The design and specifications are subject to change without notice for improvement.

• Accessory

Microphone holder (For handheld microphone)

Color rings (6 colors) (For handheld microphone)