



OPERATING INSTRUCTIONS

LINE ARRAY SPEAKERS

SR-S4LWP

SR-S4SWP

EXTENSION PLATE (optional)

SR-EP4WP

PROTECTION PAD (optional)

SR-PP4

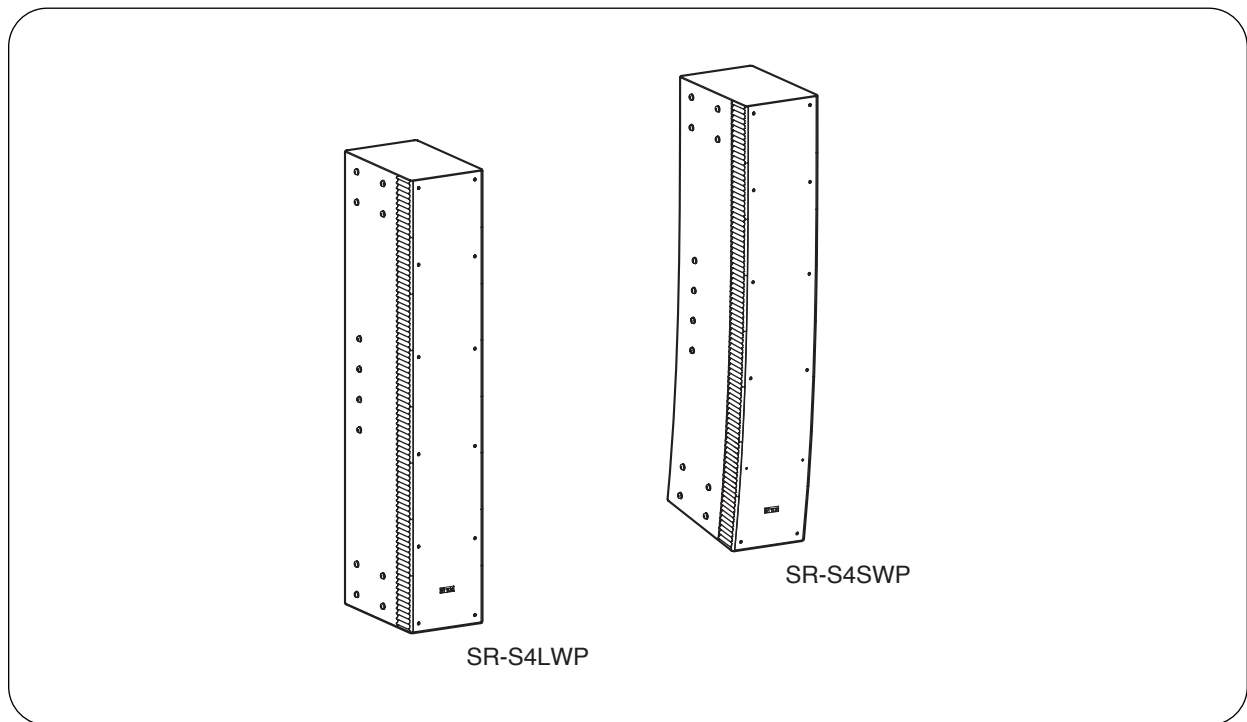

Thank you for purchasing TOA's Line Array Speakers and their associated products.
Please carefully follow the instructions in this manual to ensure long, trouble-free use of your equipment.

TABLE OF CONTENTS

1. SAFETY PRECAUTIONS	3
2. GENERAL DESCRIPTION	5
3. FEATURES	5
4. INSTALLATION PRECAUTION	6
5. COVERAGE AREA	7
6. DIMENSIONAL DIAGRAM	
6.1. Line Array Speaker SR-S4LWP	8
6.2. Line Array Speaker SR-S4SWP	8
7. SINGLE-AMPLIFIER DRIVE AND BI-AMPLIFIER DRIVE	9
8. INTERNAL WIRING DIAGRAM	9
9. CHANGING TO HIGH IMPEDANCE	10
10. JOINING SPEAKERS	11
11. ATTACHING THE PROTECTION PAD TO THE SPEAKER EDGE	12
12. CHANGING SINGLE-AMPLIFIER DRIVE TO BI-AMPLIFIER DRIVE SYSTEM	13
13. INTERNAL WIRING DIAGRAM FOR THE BI-AMPLIFIER DRIVE SYSTEM	14
14. DIGITAL PROCESSOR FILTERING	
14.1. Single-Amplifier Drive (Factory-Setting)	14
14.2. Bi-Amplifier Drive	14
15. SPECIFICATIONS	
15.1. Line Array Speaker SR-S4LWP, SR-S4SWP	15
15.2. Extension Plate SR-EP4WP (optional)	16
15.3. Protection Pad SR-PP4 (optional)	16

1. SAFETY PRECAUTIONS

- Before installation or use, be sure to carefully read all the instructions in this section for correct and safe operation.
- Be sure to follow all the precautionary instructions in this section, which contain important warnings and/or cautions regarding safety.
- After reading, keep this manual handy for future reference.

Safety Symbol and Message Conventions

Safety symbols and messages described below are used in this manual to prevent bodily injury and property damage which could result from mishandling. Before operating your product, read this manual first and understand the safety symbols and messages so you are thoroughly aware of the potential safety hazards.



WARNING

Indicates a potentially hazardous situation which, if mishandled, could result in death or serious personal injury.

When Installing the Unit

- Avoid installing or mounting the unit in unstable locations, such as on a rickety table or a slanted surface. Doing so may result in the unit falling down and causing personal injury and/or property damage.
- Refer all installation work to the dealer from whom the speaker was purchased. Installation requires extensive technical knowledge and experience. The speaker may fall off if incorrectly installed, resulting in possible personal injury.
- Flying Precautions
Be sure to follow the instructions below. Otherwise, the suspension wires or belts may be off or snap and the speaker may fall off, causing personal injury.
 - Check to confirm that the suspension wires and belts are strong enough to withstand the speaker load.
 - The connectors of the suspension wires and belts must be securely linked with those of the speaker.
 - All parts and components (such as enclosures, metal pieces, and screws) must be free from any deformation, crack, and corrosion.
 - Be sure to use screws supplied with the optional flying hardware when installing the speaker using such hardware.
- Install the unit only in a location that can structurally support the weight of the unit and the mounting bracket. Doing otherwise may result in the unit falling down and causing personal injury and/or property damage.
- When installing the unit in the snowy area, take appropriate measures to prevent snow from lying on the unit. If the snow lies on the unit, the unit may fall, causing personal injuries.
- Owing to the unit's size and weight, be sure that at least two persons are available to install the unit. Failure to do so could result in personal injury.
- Do not use other methods than specified to install the speaker. Extreme force is applied to the unit and the unit could fall off, possibly resulting in personal injuries.
- Use nuts and bolts that are appropriate for the ceiling's or wall's structure and composition. Failure to do so may cause the speaker to fall, resulting in material damage and possible personal injury.
- Tighten each nut and bolt securely. Ensure that the bracket has no loose joints after installation to prevent accidents that could result in personal injury.
- Use the specified mounting bracket in combination. Doing otherwise may cause the unit or component to fall off, resulting in personal injury.
- Do not mount the unit in locations exposed to constant vibration. The mounting bracket can be damaged by excessive vibration, potentially causing the unit to fall, which could result in personal injury.



CAUTION

Indicates a potentially hazardous situation which, if mishandled, could result in moderate or minor personal injury, and/or property damage.

When Installing the Unit

- Avoid placing the unit in a doorway or other high traffic area as people may trip on the equipment and cords, or be injured by falling objects.
- Avoid touching the unit's sharp metal edge to prevent injury.
- When installing the speaker at head height, attach the optional SR-PP4 Protection Pad to the bottom of the speaker. Failure to do so may cause injury if people hit their heads directly against the speaker.

When the Unit is in Use

- Do not operate the unit for an extended period of time with the sound distorting. This is an indication of a malfunction, which in turn can cause heat to generate and result in a fire.
- Do not stand or sit on, nor hang down from the unit as this may cause it to fall down or drop, resulting in personal injury and/or property damage.
- Have the unit checked periodically by the shop from where it was purchased. Failure to do so may result in corrosion or damage to the unit or its mounting bracket that could cause the unit to fall, possibly causing personal injury.

2. GENERAL DESCRIPTION

Featuring slim construction, the SR-S4 series are 2-way line array speakers containing 32 speaker elements. The sound source speaker elements are vertically arranged in close proximity to each other, and form a continuous linear sound source, achieving uniform sound pressure with less attenuation due to distance.

The SR-S4LWP speaker is of a linear design which is ideal for long distance sound transmission applications, while the SR-S4SWP features a curved line having a 10° vertical coverage area, and is designed to cover relatively short distance applications.

It is also possible to combine both the linear and curved line types to configure an array that continuously covers applications ranging from short to long distances.

3. FEATURES

- The SR-S4 series is a 2-way line array speaker having eight 10 cm woofers for low-frequency output, and 24 small tweeters for high-frequency sound output. Both the woofers and tweeters are arranged in the front and rear on the same axis, providing a symmetrical, uniform coverage area.
- Since the linear sound source effect prevents energy from attenuating even at longer distances, the line array speaker compares favorably with normal types of speakers in its ability to project sound long distances. This realizes less difference in sound volume between areas close and far from the speaker, for a more uniform sound field.
- Since the speaker's vertical sound dispersion is suppressed, sound is only directed at the target area. The speaker's construction is not influenced by sound reflection from ceiling or floor surfaces, and can provide clear sounds even in spaces affected by long reverberation times or other poor acoustic conditions.
- Since the attenuation of sound pressure is small even far away from the speaker, the volume is not excessively loud in the area near the speaker. This helps suppress feedback (improving safety amplification gain).
- By joining 2 or 3 speakers, a longer sound source can be configured, making it possible to project sound output farther and at larger volumes.
- The speaker has a built-in network circuit for a single amplifier drive. Changing the internal connector position enables bi-amplifier drive that provides a higher quality sound output.
- The use of optional SR-WB4WP Wall mounting bracket and SR-TB4WP Wall tilt bracket permits the speaker to be installed in the most appropriate position for its intended use. (Details of the installation procedures are described in the installation manual enclosed with each bracket.)
- The speaker can be used for high-impedance applications with the additional use of the optional MT-S0601 Matching transformer. (Single-amplifier drive only)

4. INSTALLATION PRECAUTION

CAUTION

When permanently installing the speaker outdoors, inspect it periodically. Damage or corrosion of the speaker or mounting hardware could cause the speaker to fall, possibly resulting in personal injury.

- The SR-S4LWP and SR-S4SWP speakers feature water protection construction (IPX4), however it is recommended that they be installed under roofs, eaves, or in other locations not directly exposed to rain or snow.
- Take care not to install the speaker upside-down relative to the "UP" mark affixed to the speaker's rear panel.
- Do not install the speaker horizontally.

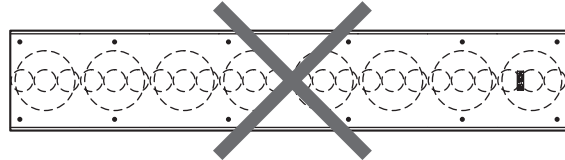

- The downward angle must be within 45° for the SR-S4LWP and within 30° for the SR-S4SWP.

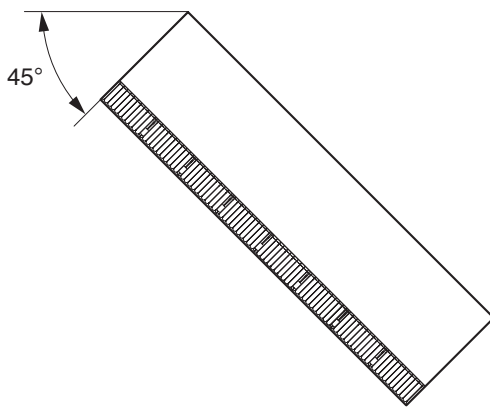

[SR-S4LWP]

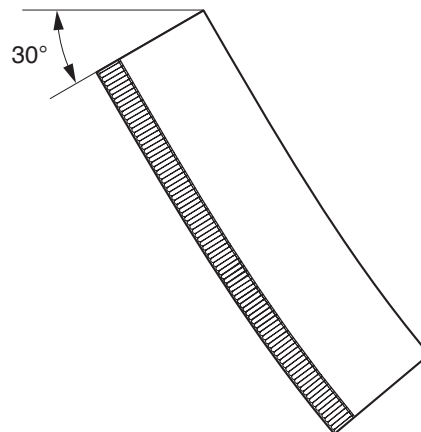

[SR-S4SWP]

5. COVERAGE AREA

The line array speaker radiates a sound only within a limited range. Since sound is reduced in areas that are outside the range, take care that the listening area is sufficiently covered when installing the speaker.

• Correct installation examples

[SR-S4LWP x 2]

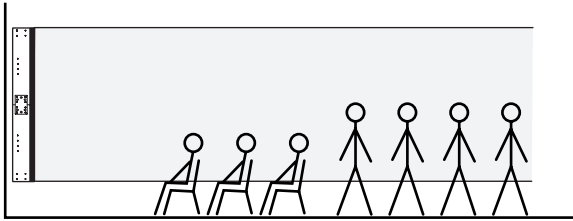

[SR-S4SWP]

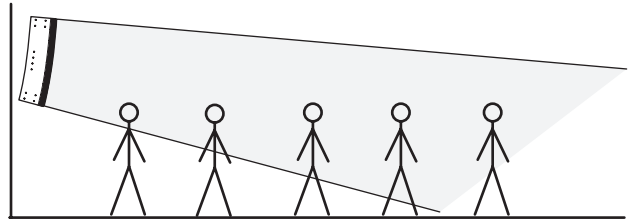

[SR-S4LWP + SR-S4SWP]

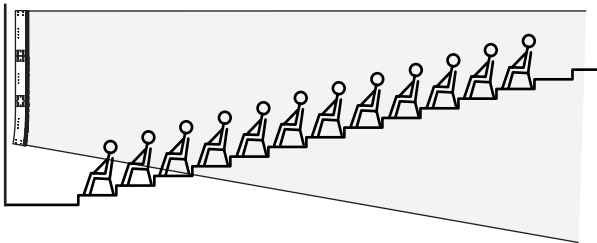

• Incorrect installation examples

If the speaker is installed high above the floor facing horizontally or diagonally downward at a large angle, the listening area cannot be covered sufficiently.

[SR-S4LWP]



[SR-S4SWP]

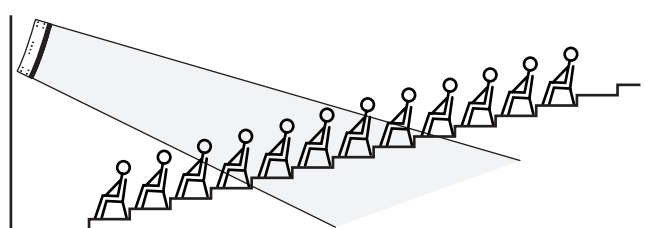

6. DIMENSIONAL DIAGRAM

6.1. Line Array Speaker SR-S4LWP

Unit: mm

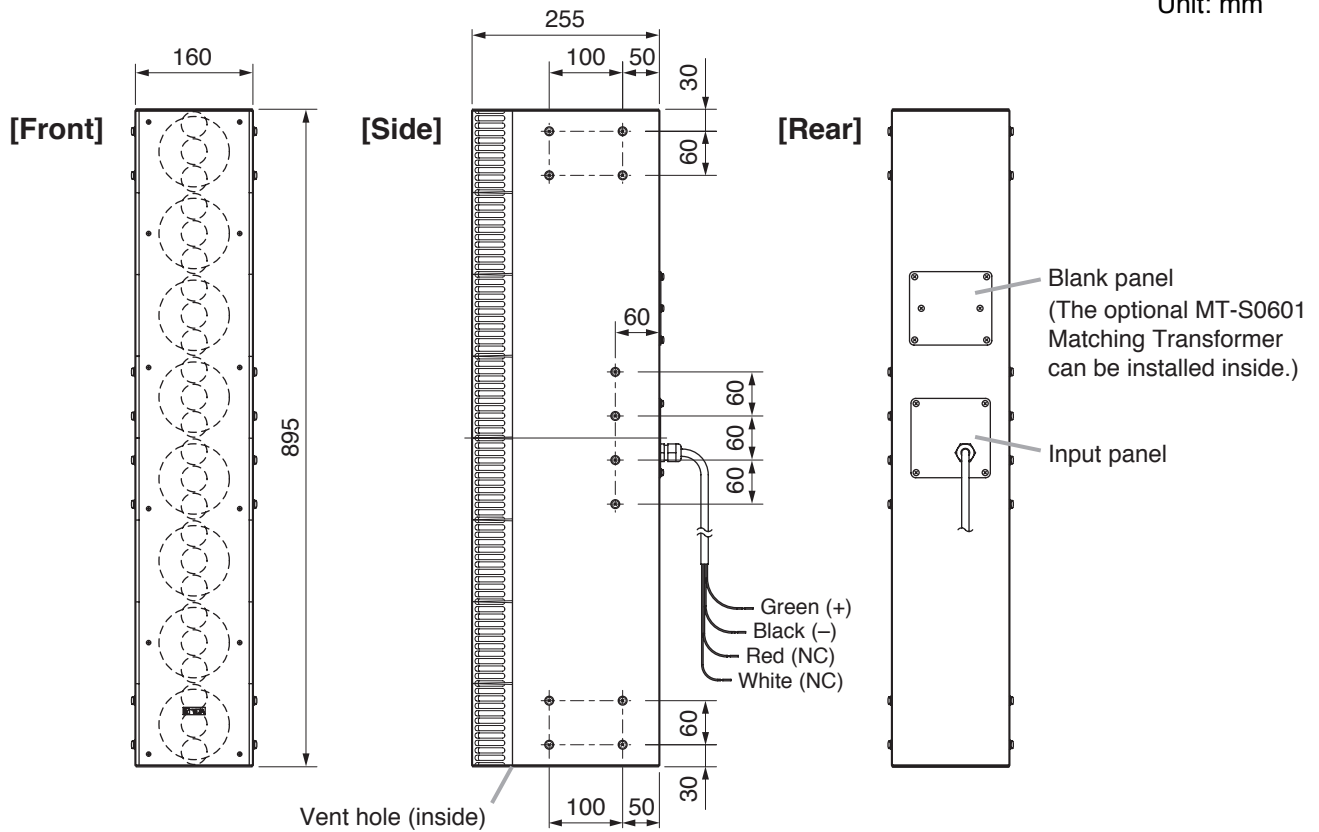

6.2. Line Array Speaker SR-S4SWP

Unit: mm

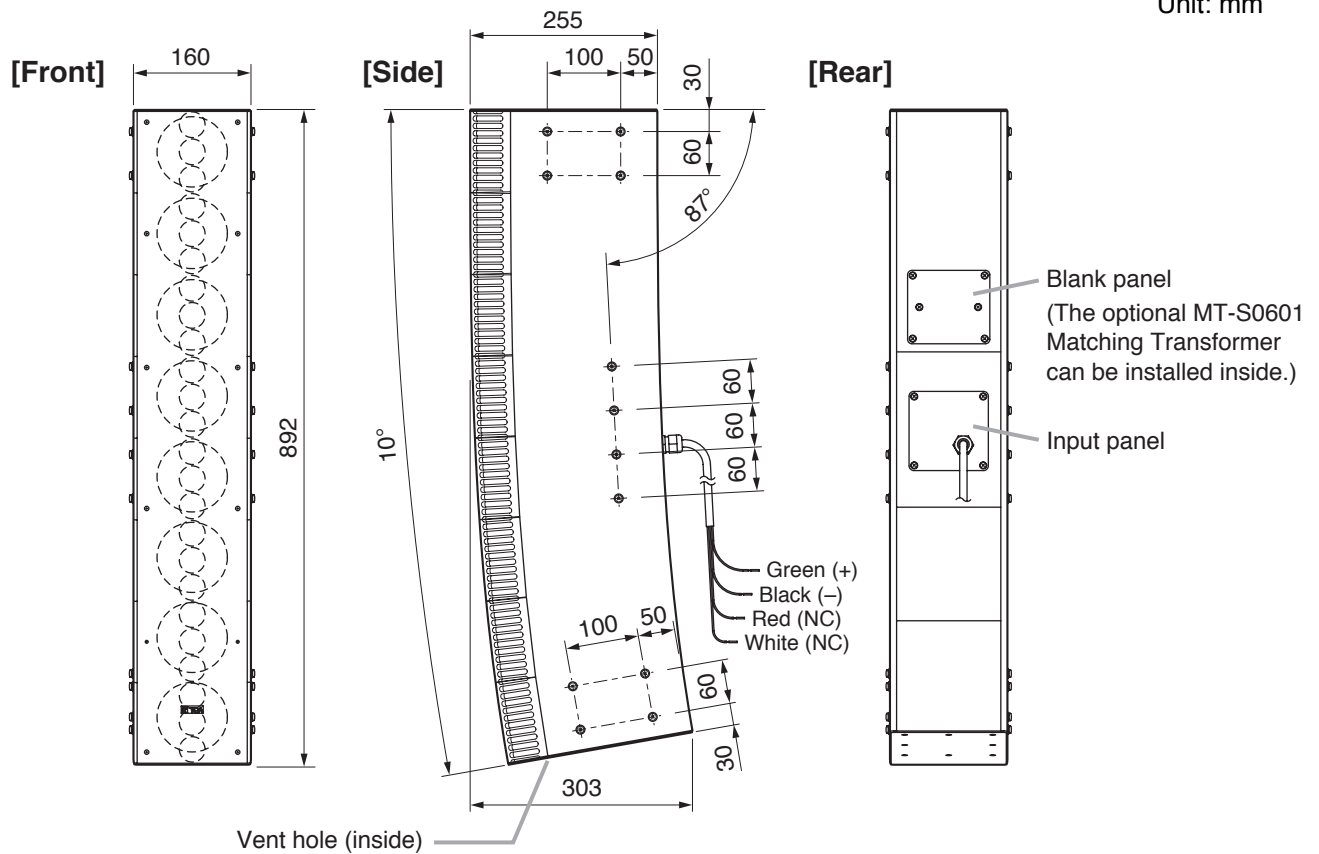

7. SINGLE-AMPLIFIER DRIVE AND BI-AMPLIFIER DRIVE

The SR-S4 series speakers are factory-preset to be driven by a single amplifier, however this setting can be changed to a bi-amplifier drive system by changing the speaker's internal wiring. (See p. 13; Changing Single-Amplifier Drive to Bi-Amplifier Drive System.)

• Single-amplifier drive

Note: Use a digital processor as required.

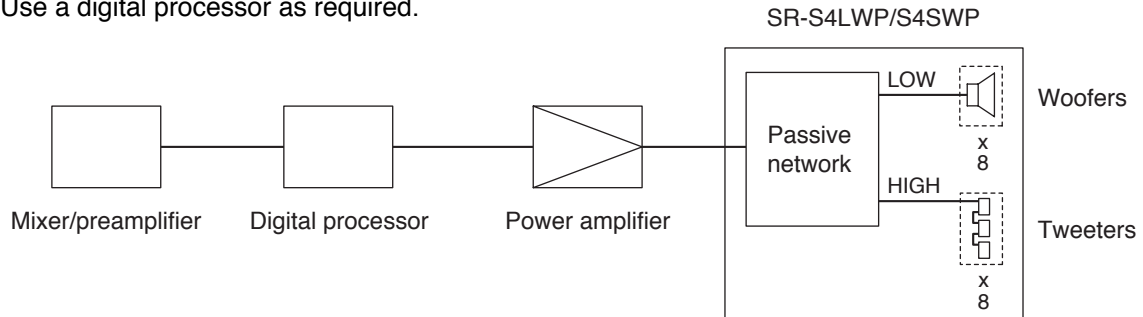

• Bi-amplifier drive

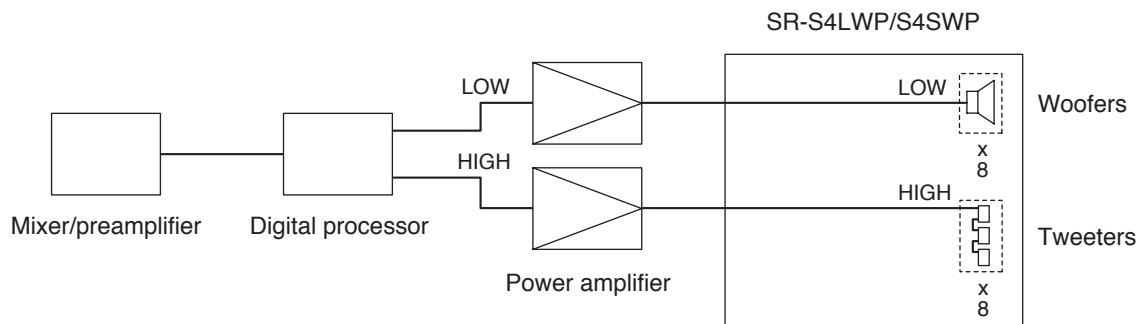

8. INTERNAL WIRING DIAGRAM

When shipped from the factory, the speaker is internally connected as shown below.

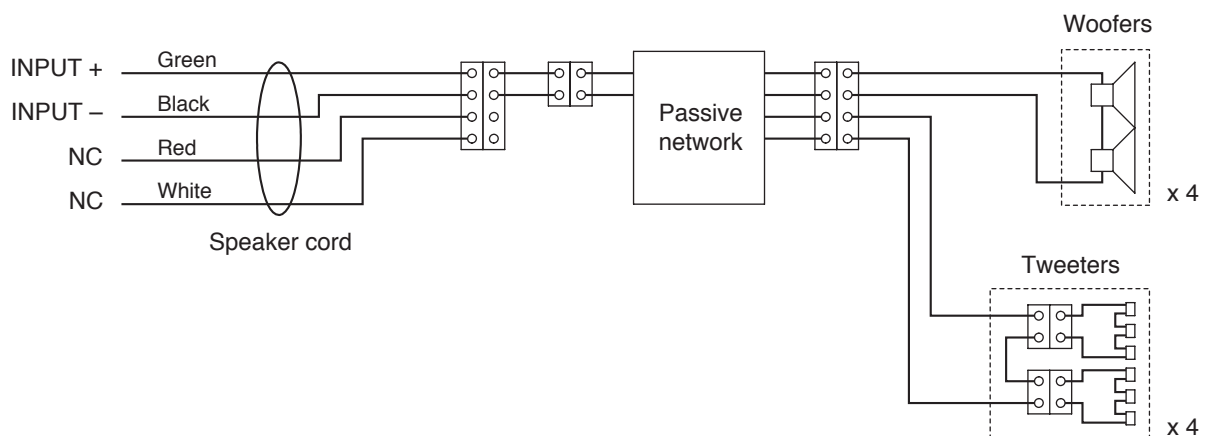

9. CHANGING TO HIGH IMPEDANCE

The SR-S4 series speakers can be used for high-impedance applications with the installation of the optional MT-S0601 Matching Transformer.

To install the MT-S0601 transformer, remove the blank panel located on the speaker's rear panel.

For details regarding mounting procedures, refer to the instruction manual enclosed with the MT-S0601.

Note

The speaker cannot be used in combination with the matching transformer when driven by a bi-amplifier.

SR-S4LWP/S4SWP
Rear panel

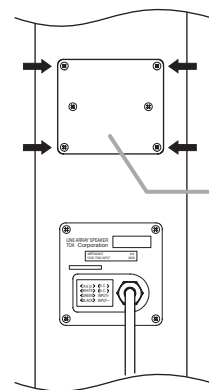

Blank panel
(Remove the 4 screws indicated by arrows.)

To change the tap, refer to the instruction manual enclosed with the MT-S0601.

Primary side impedance	High impedance 100 V line	High impedance 70 V line
83 Ω	Unusable	60 W
170 Ω	60 W	30 W
330 Ω	30 W	15 W
670 Ω	15 W	7.5 W

The diagram below is an internal wiring when the matching transformer is installed.

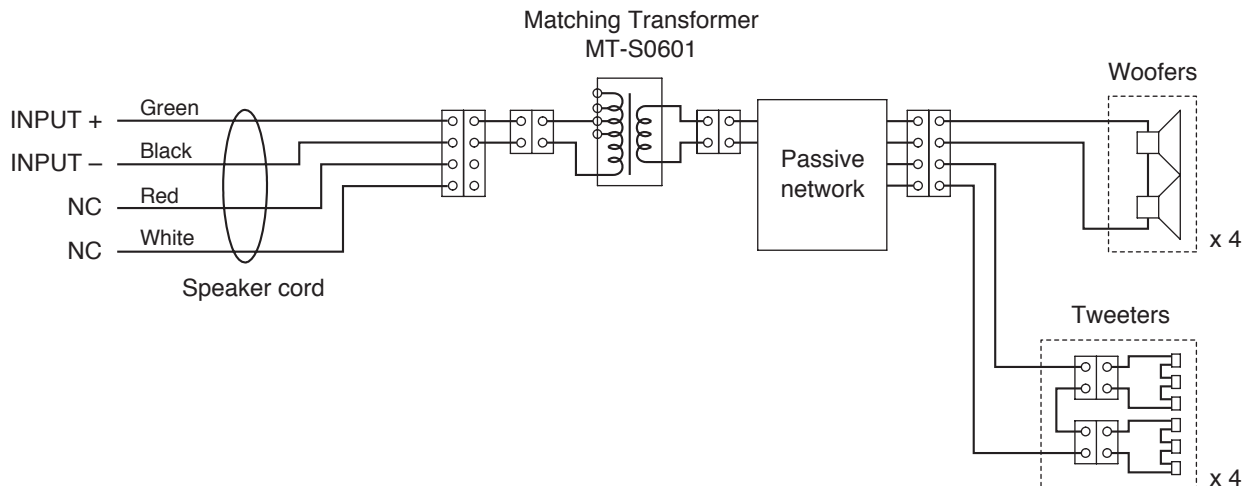

10. JOINING SPEAKERS

Joining line array speakers configures a longer linear sound source, permitting richer low-frequency sound reproduction as well as transmission of higher sound output over a longer distance. To join speakers, use the optional SR-EP4WP Extension plate.

[Joining Procedure]

Step 1. Remove the screws and washers (for waterproof) on both sides of the speaker.

Step 2. Join the 2 speakers using the SR-EP4WP Extension plate and the screws and washers removed in Step 1. In this event, orient the bracket's waterproof pad side toward the speaker's side.

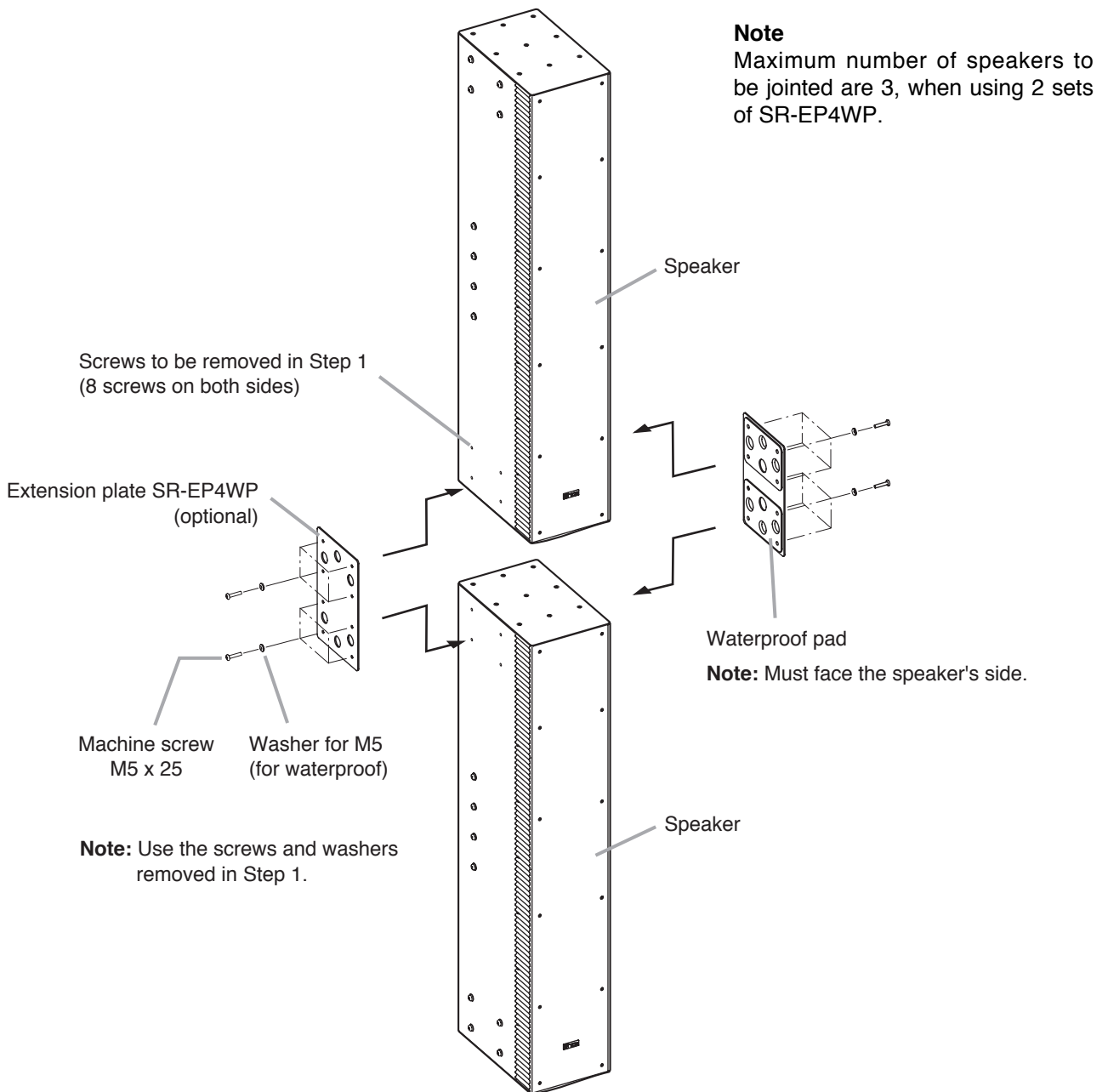

11. ATTACHING THE PROTECTION PAD TO THE SPEAKER EDGE

CAUTION

When installing the speaker at head height, attach the optional SR-RP4 Protection Pad to the speaker edges. If people should bump their heads directly against the corners or edges of the enclosure, injuries could result.

After removing the protective paper of the double-faced tape affixed to the optional SR-PP4 Protection Pad, apply a commercial rubber adhesive to the portion not covered by tape, then affix the pad to the speaker's edge.

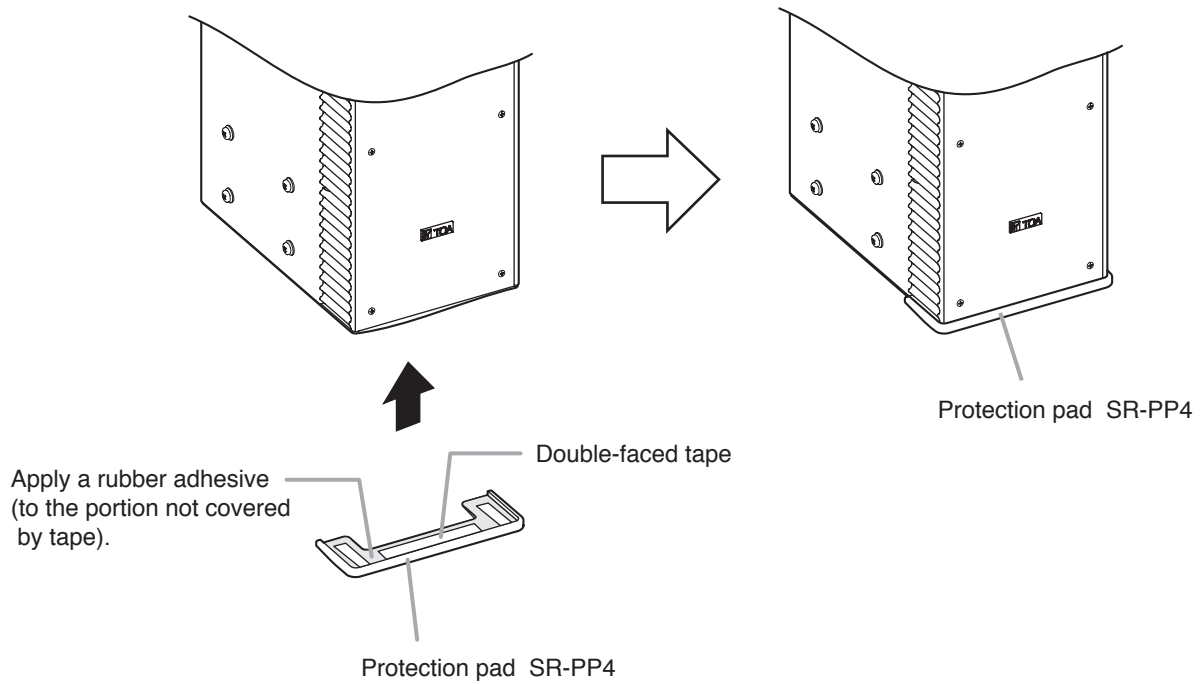

12. CHANGING SINGLE-AMPLIFIER DRIVE TO BI-AMPLIFIER DRIVE SYSTEM

The single-amplifier drive system can be changed to a bi-amplifier drive system by changing the speaker's internal wiring after removing the input panel located at the back of the speaker.

[How to change]

Step 1. Remove the 4 Input panel mounting screws to remove the input panel.

Step 2. Carefully pull out the short length of wiring connected to the back of the input panel.

Step 3. Unplug 2 pairs of connected connectors, and reconnect them so that connections are made between labeled connectors and between unlabeled connectors.

Step 4. Reattach the input panel to the speaker using the 4 screws.

Step 5. Affix the supplied label to the input panel to change the indication.

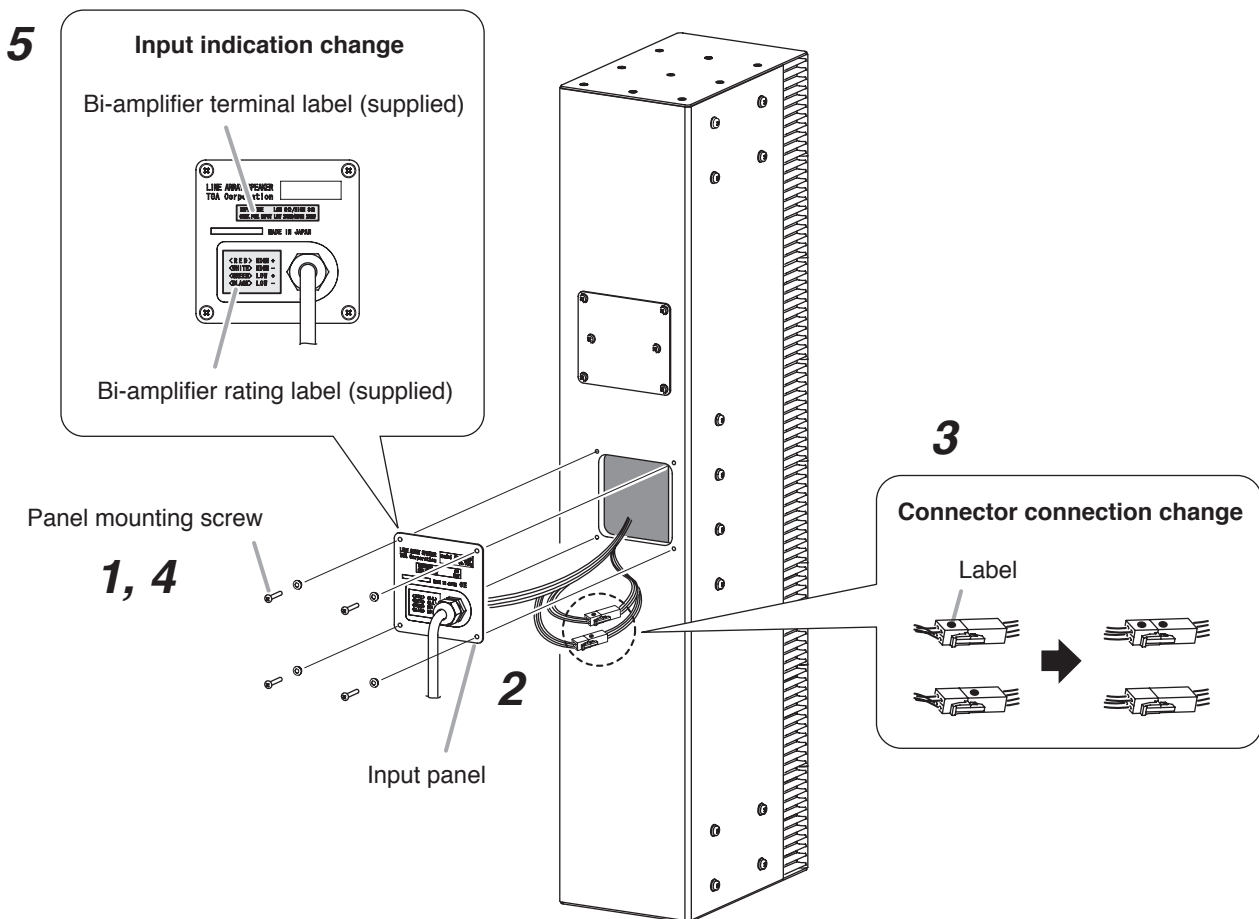

13. INTERNAL WIRING DIAGRAM FOR THE BI-AMPLIFIER DRIVE SYSTEM

The diagram below is an internal wiring after the speaker's drive system is changed to a bi-amplifier system.

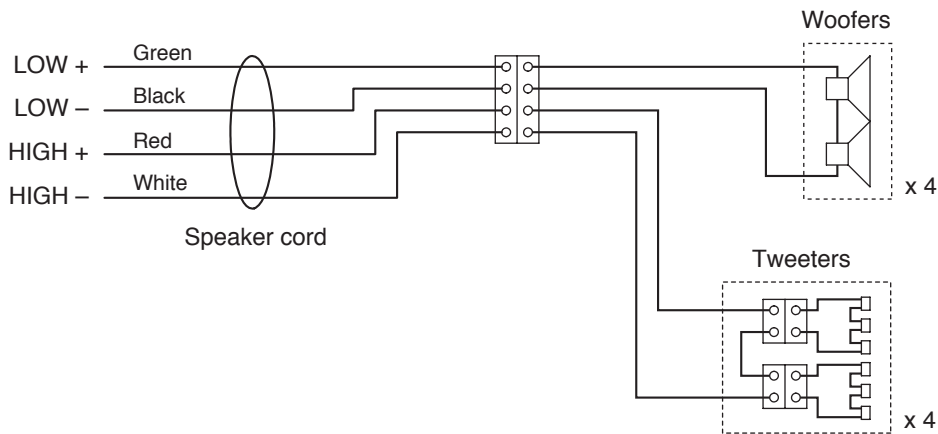

14. DIGITAL PROCESSOR FILTERING

14.1. Single-Amplifier Drive (Factory-Setting)

Although the speaker can be operated without a digital processor, it is recommended that the speaker be used in conjunction with a digital processor for better sound reproduction. Recommended setting parameters are as follows.

TYPE	Frequency	Gain	Q
HPF (12 dB)	60 Hz	—	1.226
PEQ	16 kHz	5 dB	1.414

14.2. Bi-Amplifier Drive

Digital processing is required after the drive system has been changed to bi-amplifier operation. By inputting an optimum signal to the woofer and tweeter using the digital processor, a high sound quality output can be realized. Recommended setting parameters are as follows.

Channel	Gain	Polarity	Filter				Delay
			TYPE	Frequency	Gain	Q	
LOW	0 dB	Normal	HPF (12 dB)	60 Hz	—	1.226	0 ms
			PEQ	63 Hz	2 dB	1.707	
			PEQ	1.5 kHz	-5 dB	0.700	
			LPF (12 dB)	4.0 kHz	—	0.500	
HIGH	-2 dB	Normal	HPF(12 dB)	4.0 kHz	—	0.707	0.125 ms
			PEQ	4.0 kHz	3 dB	2.997	
			PEQ	6.3 kHz	-3 dB	1.512	
			PEQ	16.0 kHz	5 dB	1.414	

15. SPECIFICATIONS

15.1. Line Array Speaker SR-S4LWP, SR-S4SWP

Model No.	SR-S4LWP	SR-S4SWP
Enclosure	Sealed type	
Power Handling Capacity	Continuous program: 600 W	
Rated Impedance	8 Ω	
Sensitivity	94 dB (1 W, 1 m)	93 dB (1 W, 1 m)
Frequency Response	70 – 20,000 Hz (when using the optional DP-0206 Digital processor)	
Crossover Frequency	3,500 Hz	
Directivity Angle	Horizontal: 90° Vertical: 0° (within the range of speaker height)	Horizontal: 90° Vertical: 10°
Speaker Component	Low frequency: 10 cm cone-type x 8 High frequency: 2.5 cm balanced dome-type x 24	
Connected Cable	Direct cable withdrawal from internal speaker: ø8.6 mm, conductor cross section: 1.25 mm ² , 4-core cable, 3 m	
Water Protection	IPX4	
Finish	Enclosure: Plywood, white, urethan coating Front grille: Punched stainless steel (SUS304), white, paint	
Dimensions	160 (w) x 895 (h) x 255 (d) mm	160 (w) x 892 (h) x 303 (d) mm
Weight	16 kg	

Note: The design and specifications are subject to change without notice for improvement.

• Accessories

Bi-amplifier rating label 1

Bi-amplifier terminal label 1

• Optional products

Matching transformer: MT-S0601

Extension plate: SR-EP4WP

Wall tilt bracket: SR-TB4WP

Wall mounting bracket: SR-WB4WP (Applicable to the SR-S4LWP only)

Protection pad: SR-PP4

Digital processor: DP-0206

15.2. Extension Plate SR-EP4WP (optional)

The SR-EP4WP is used to join multiple SR-S4LWP or SR-S4SWP speakers. One complete set consists of 2 brackets.

Number of Speaker to be Jointed	Max. 3 (when using 2 sets of SR-EP4WP)
Finish	Stainless steel (SUS304)
Dimensions	140 (w) x 220 (h) x 4 (t) mm
Weight	900 g

Notes

- The fixing screws are not supplied with the unit. Use the attached screws on both sides of speaker.
- The design and specifications are subject to change without notice for improvement.

15.3. Protection Pad SR-PP4 (optional)

When the SR-S4LWP or SR-S4SWP speaker is installed so that its bottom edge is located at head height, people could bump their heads directly against the speaker and suffer injuries. Affixing this protection pad to the speaker's bottom surface helps reduce the impact and chance of injury.

Finish	Synthetic rubber, black
Dimensions	168 (w) x 59 (d) x 8 (t) mm
Weight	40 g

Note: The design and specifications are subject to change without notice for improvement.

Traceability Information for Europe

Manufacturer:
TOA Corporation
7-2-1, Minatojima-Nakamachi, Chuo-ku, Kobe, Hyogo,
Japan

Authorized representative:
TOA Electronics Europe GmbH
Suederstrasse 282, 20537 Hamburg,
Germany

