

■ DESCRIPTION

The TS-905 is an Infrared Transmitter/Receiver of the Infrared Conference system. Since the system is cordless, it can be easily installed and removed. Communications between the TS-905 and conference units are performed by means of infrared signals and the TS-905 permits transmit and receive with the Central unit. It can be mounted not only to the ceiling and wall but on the microphone stand.

■ SPECIFICATIONS

Power Source	24 V DC (supplied from the optional TS-900 or TS-800)
Current Consumption	Max. 100 mA
Infrared Emitter/Detector	
Wavelength	870 nm (AM: Brightness modulation)
Modulation Method	Frequency modulation
Carrier Frequency	Transmission: Audio channel 1: 7.35 MHz Audio channel 2: 8.10 MHz Audio channel 3: 8.55 MHz Audio channel 4: 9.15 MHz Control channel: 6.45 MHz Reception: Base language channel: 1.95 MHz Translation language channel: 2.25 MHz
Acceptance Angle	Vertical: 150° (75° + 75°), Horizontal: 360°
Emission Angle	Vertical: 150° (75° + 75°), Horizontal: 360°
Covering Range	7 m
Connection Terminal	BNC jack
LED Indicator	Power
Operating Temperature	0°C to +40°C
Finish	Dome: PC resin, visible light cut filter Base: ABS resin, black
Dimensions	ø120 X 71.3 (H) mm
Weight	230 g (unit only)
Accessory	Mounting bracket --1, Stand mounting bracket --1
Option	Microphone stand (The mounting thread size must be W 5/16.)

■ APPEARANCE

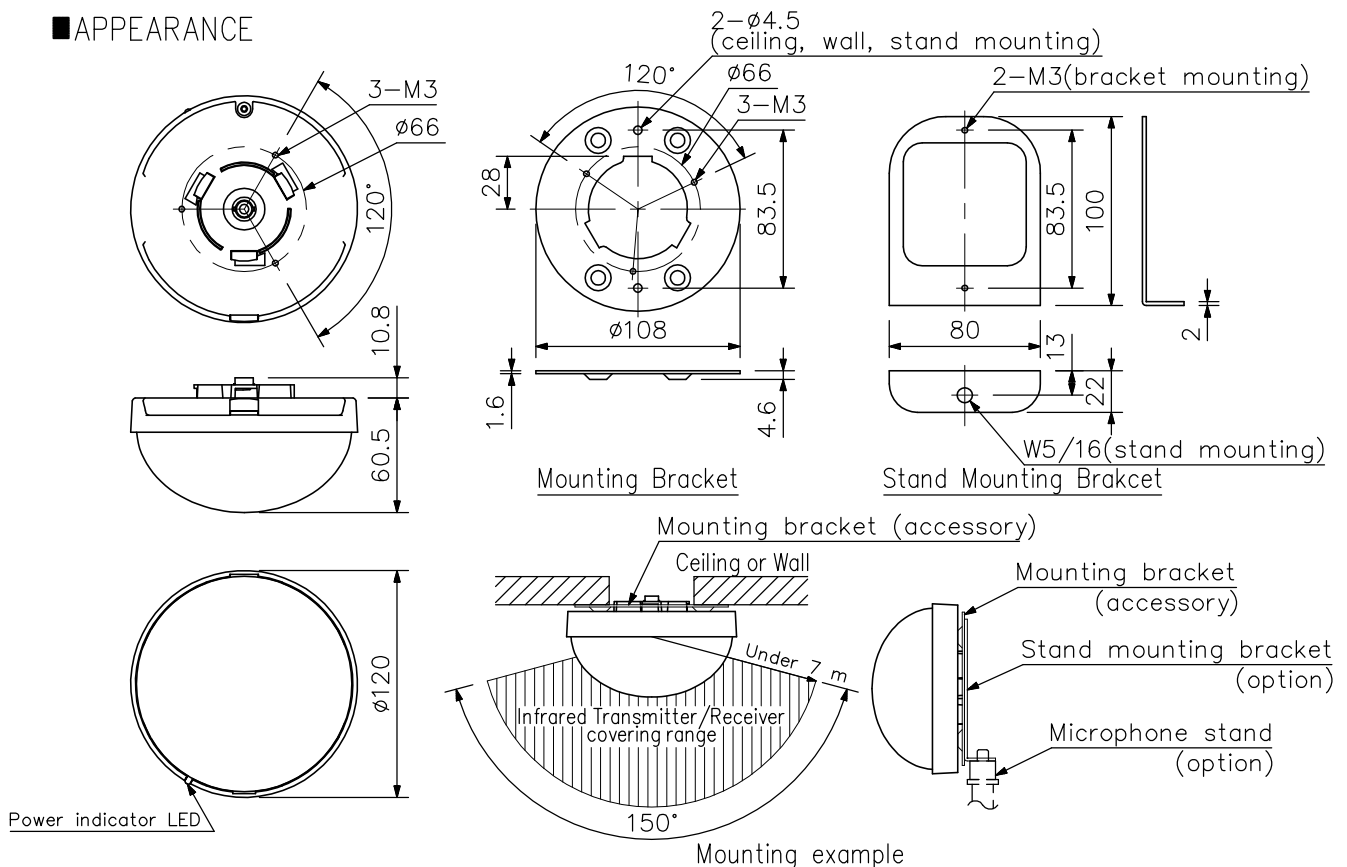

UNIT:mm SCALE:1/4